

Medium Voltage Distribution

FLUSARC

36 kV - 630 A - 25 kA

Catalogue
2010



■ Overview	3
□ General description	3
□ Main characteristics	3
■ Operating conditions	4
□ Degree of protection against accidental contact and ingress of foreign objects	4
□ Environmental and operating conditions	4
□ Standards and approvals	4
□ Maximum number of operation	4
■ Technical characteristics	5
■ Product description	6
□ Incoming / outgoing unit (C).....	9
□ Transformer protection unit (T1)	9
□ Fuse selection table	9
□ Unit with vacuum circuit-breaker (CB)	10
□ Direct incoming / outgoing unit (R)	11
□ Outdoor switchgear	11
□ Operation counter	12
□ Undervoltage release (UVR).....	12
□ Undervoltage release control card	12
□ Shunt closing release.....	12
■ Accessories	12
□ Shunt opening release	13
□ Demagnetization opening solenoid	13
□ Toroidal current transformer	13
□ Gear motor for loading springs	13
□ Line control gear motor	14
□ Auxiliary contacts	14
□ Voltage presence signal lamp	14
□ Loaded or unloaded closing springs' signalling contact.....	14
□ Diode rectifier bridge	15
□ Protection unit	15
• Protection relay VPR-SP1	15
• Protection relay VPR-P1	15
■ Operation safety	16
□ Safety system.....	16
□ Interlocks for functions C and T1	17
□ Interlocks for function CB	17
■ Operator interface	18
■ Operating accessories	20
■ Cables connection	20
■ Ecological considerations	21
■ Installation	22
■ Dimension and weights	24
■ Shipping	26
□ Packing.....	26
□ Transport	26
□ Handling	26
■ Notes	27

KJAB200



Assembly view of some possible FLUSARC switchgear configurations

General description

The FLUSARC apparatuses are medium voltage switchgear, suitable for 36 kV rated voltage and specifically conceived for the secondary distribution substations in M.V. with either ring or radial type networks.

They indeed allow to connect two up to five lines of the M.V. network, and assure both the power supply and the protection of M.V./L.V. transformers for L.V. users. The FLUSARC switchgear belong to the protected type for indoor and outdoor use, and use the low pressure gas SF₆ both for insulating the switchgear itself and for interrupting the electric arc within switch disconnecter. The CB is of vacuum type. The FLUSARC switchgear is available in two different type:

- modular: every function is inside its own tank filled with SF₆
- compact: all the functions are contained inside the same tank filled with SF₆. At most five functions.

Main characteristics

The FLUSARC switchgear assures a personnel high safety level, obtained by using the following precautions:

- direct earthing of the switchgear whole structure;
- total segregation of the live parts, which are contained inside a stainless steel housing, hermetically sealed and filled with gas SF₆;
- accessibility to the fuses without any danger, with preventive earthing of the two ends;
- availability of earthing switches with making capacity;
- mechanical interlocks, granting the exact sequence of the operations.

Using the gas SF₆ prevents any possible arising of fires. A safety valve against overpressures, situated under the switchgear, allows the gas to flow out, so avoiding any possible danger for the operator, while a pressure gauge allows the continuous monitoring of the pressure inside the metal housing.

The insulation with gas SF₆ of all the parts under voltage besides reduces to the minimum the possibility of faults between the phases or toward the earth.

With low pressure gas (0.3 bar, relative pressure), the sealing systems are simple and reliable, so granting a good operation for at least 20 years, without needing to reset the pressure.

The operation is anyway granted, with unchanged characteristics, even with a relative pressure equal to 0. The switchgear is insensitive to the outside ambient conditions and therefore particularly fit for being installed in presence of industrial pollution or of a salty, wet climate. Besides, those switchgear can also operate fully immersed in water for a given time.

All the control operations are executed by acting on the switchgear front side through easy and functional devices, with mechanical signalings about the position of the different components. Clear instructions for executing the operations are reported on the switchgear front side.

The switchgear have a limited height and small dimensions. Consequently, the following advantages are assured:

- very small dimensioned installation rooms (such as cabins, cellars, mobile substations, etc.);
- small and cheap infrastructures;
- low costs for transport and installation.

The FLUSARC switchgear actually do not need any maintenance interventions, and neither settings or gas fillings have to be executed during the apparatus whole lifetime.

FLUSARC switchgear units are:

- SF₆ insulated
- pre-fabricated and type-tested
- arc resistant

Degree of protection against accidental contact and ingress of foreign objects

Main electric circuits	IP67
Fuses compartment	IP4X
Operating mechanisms	IP3X
Cables connection compartment	IP3X

Environmental and operating conditions

FLUSARC switchgear units must be installed and operated in normal conditions as specified in EN 60694 or IEC 60694.

Operation under conditions other than these is only permissible after consultation with the manufacturer and obtaining written consent.

Ambient conditions		
Temperature class		"minus 5 indoor"
Average value over 24 hours (max.)	°C	35
Maximum installation altitude above sea level	m	1000
Insulating gas		
Type		Sulphur hexafluoride (SF ₆)
Rated pressure pre at 20 °C	MPa	0.03
Relative leakage rate F _{rel}	%	< 0.1 p.a.

Should any operating conditions in particular environments, having different characteristics with respect to the above mentioned ones, be requested, contact Schneider Electric, who will provide to customize (wherever possible) the apparatus, according with the Customer requirements.

Standards and approvals

The FLUSARC switchgears fully comply with the IEC 62271-100, IEC 62271-200 and IEC 60694 Standards.

Maximum number of operation

In the following curves, the admitted number of operations (closing/opening cycles) of the vacuum circuit- breakers, according with the breaking current (rms), is indicated.

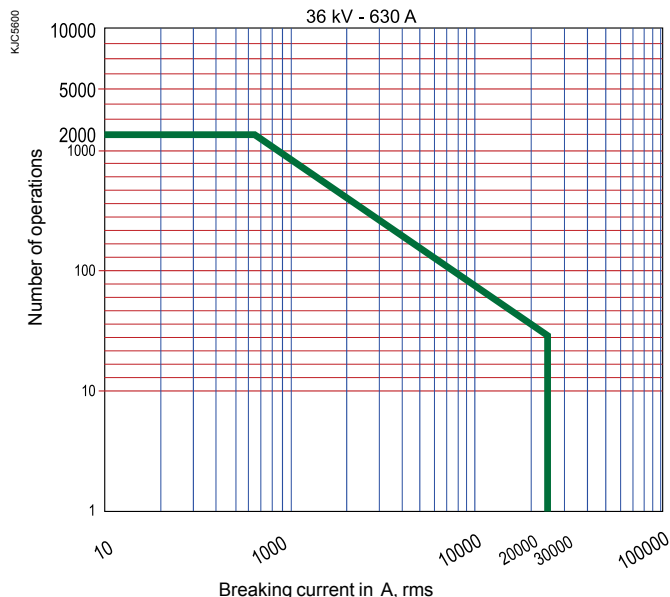

Electric data common to all the switchgear		
Rated voltage	Ur[kV]	36
Rated power frequency withstand voltage (50/60 Hz 1 min.): ■ towards the ground and between phases ■ across the isolating distance	Ud[kV]	■ 70 ■ 80
Rated lightning impulse withstand voltage: ■ towards the ground and between phases ■ across the isolating distance	Up[kV]	■ 170 ■ 195
Internal arc withstand current 1 s	[kA]	16 / 20
Continuity of service		LSC2A (according to IEC 62271 – 200)
Rated current	Ir[A]	630
Bus bar rated current	[kA]	630 (compact) 1250 (modular)
Breaking capacity of active circuits (cos. φ 0.7) and ring circuits at 0.3 Vn	I1-I2a[A]	630
Breaking capacity of no-load transformers	I3[A]	25
Breaking capacity of no-load lines/cables	I4a-I4b[A]	25
Short time withstand current 1 s on main circuits and earth circuits	I _k [kA]	16 / 25
Short time withstand current 3 s on main circuits and earth circuits	I _k [kA]	20
Switch disconnecter making capacity and earthing switch making capacity	I _{ma} [kA]	40 / 62.5
Water proof test 0,3 bar	[kV]	70 kV x 1 min. – Vn x 24 hours
Electrical life test		100 operations CO at 630 A
Rated filling pressure Pme ³)		130 kPa (absolute at 20 °C)
Ambient temperature		-5 °C / + 40 °C
Making capacity of switch disconnecter and fuse switch disconnecter		Nr. 2 operations – Close Open at 63 kA Nr. 5 operations – Close Open at 40 kA
Switching unit for protection electrical data		
Transfer current	I _t [A]	800
Normal current of the fuse	[A]	63
Short circuit making current	[kA]	78.75
Short circuit breaking current	[kA]	31.5
Short time current on earthing switch downstream of fuses	I _k [kA]	-
Circuit-breaker unit electrical data		
Breaking capacity of Circuit-Breaker	[kA]	16/25
Circuit-Breaker rated switching sequence		O - 0,3 s - CO - 3 min CO - 3 min - CO
Number of mechanical operations of switch disconnecter and earthing switch	n	1000
Number of mechanical operations of Circuit-Breaker	n	2000

The FLUSARC switchgear consists of a stainless steel metal housing, suitably welded in order to assure the sealing of the gas SF₆. Inside the switchgear, the switch-disconnectors (from 1 up to 5 units), the earthing switches, the possible three fuses units (either 1 or 2 units) for the transformer protection, the bushings for the cables connection and the omnibus bars of the primary circuit, are housed.

The so composed housing is mounted on a firm supporting base, manufactured in previously zinc-plated sheet steel.

The moving components and the accessible parts are protected by some purposed protective boxes, realized in carbon sheet steel (P11) and powder painted.

Main components

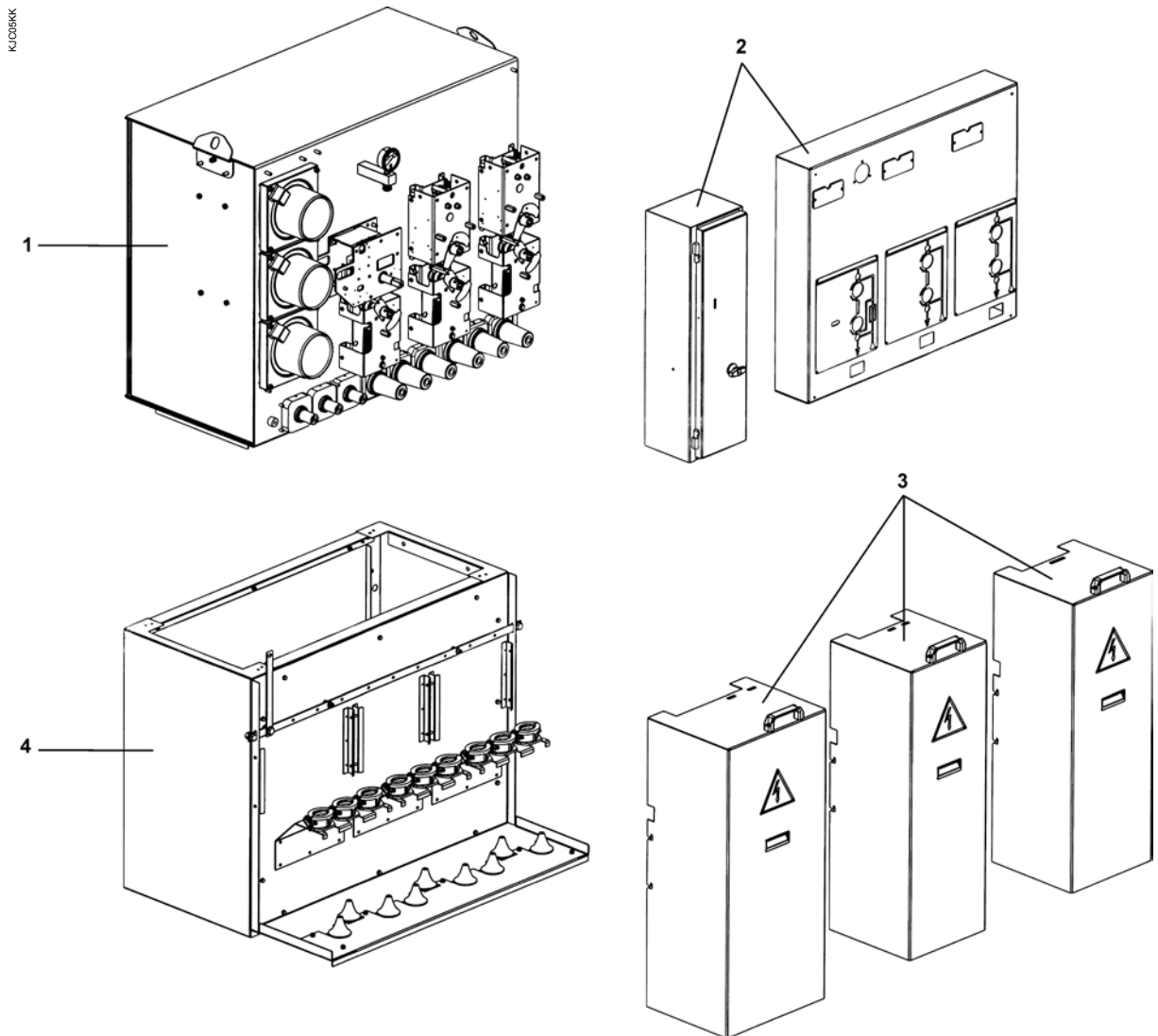

Legend

- 1. Metal housing with gas SF₆
- 2. Upper protective boxes
- 3. Lower protective boxes
- 4. Supporting base



Bushing for cables connection

The bushings for the cables connection are manufactured in epoxy resin reinforced with quartz, as well as the insulating bushings/M.V. fuses boxes.



Cables clamp mounting

On the supporting base, the clamp for the cables mounting are situated. Such clamps, realized in nylon reinforced with glass, can lock the M.V. cables with a cross-section from 25 up to 240 mm².



Earthing bus-bar

The braids of the cables sheaths can be connected to the earthing bus-bar by means of specially purposed bolts.



Switchgear equipped with inspection windows

The operating mechanisms are of the dead center passage-type, the energy for the movement of the CB unit circuit breaker contacts is supplied by some previously compressed springs. In order to avoid any possible errors during the operations, some interlocks of hindrance type are predisposed between the operating mechanisms and between the earthing control and the fuses compartment access door. The switchgear structure houses the cable terminals support and the earth circuit external to the switchgear itself. On the protective box covering the controls and fuses, the switchgear mimic diagram is applied, and near the switch disconnect or earthing switch operating points there is a variable mimic diagram indicator, showing the state of disconnectors and fuses. On the switchgear front side (on Customer request), it is possible to mount some inspection windows, allowing to show the position of the contacts.



Pressure gauge indicating the pressure of the gas SF₆

In the switchgear front side, the pressure gauge is situated for checking the pressure of the gas SF₆.



Safety valves for allowing the gas to flow out

In case of overpressures generated by an inner arc, the FLUSARC switchgear are equipped with safety valves, for letting the gas flow out into the air, installed in the stainless steel housing lower part.



Extensibility of the switchgear

The FLUSARC switchgear can be manufactured in different configurations, according with the Customer requirements.

The units which can be combined together are the following ones:

- Incoming/outgoing unit (C)
- Transformer protection unit with fuses (T1)
- Incoming/outgoing unit with circuit-breaker (CB)
- Direct incoming/outgoing unit (R).
- An example of the versions which can be obtained is represented in paragraph "Dimensions and weights".

It is besides possible to further extend the configurations by externally connecting with purposed bus-bars several switch-gear the one to the others, provided that they were initially bought in the extensible version.

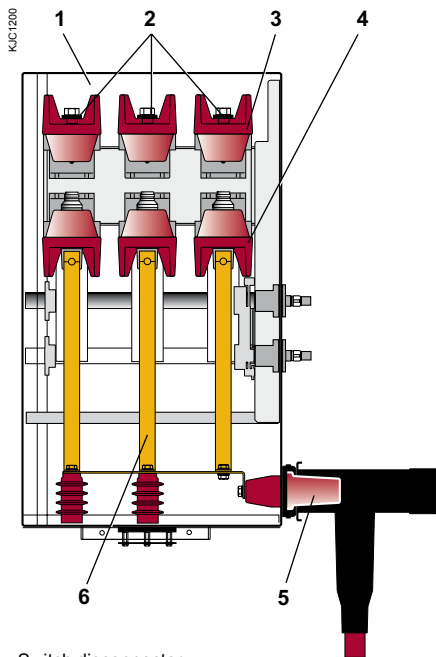

Switch disconnector

Incoming / outgoing unit (C)

The line unit consists of a switch-disconnector and an earthing switch. The switch-disconnector, consists of three poles mounted on a steel structure and connected to a common shaft, which, on its turn, is connected to the operating mechanism. The pole consists of an upper part and of a lower one, in epoxy resin. The upper part houses the fixed contacts and the connection to the bus-bars, while the lower part houses the sliding contacts, the moving contacts and the piston for the blowing action. The (line) control can be either manual or motorized (upon request). In the manual control, the only possible action is performed by means of the purposed operating lever supplied in the delivery, while in the motorized control the operation can be executed either by local or by remote control.

Legend

- 1. SF₆ gas
- 2. Main bus-bars
- 3. Upper isolating support
- 4. Lower isolating support
- 5. Bushing for cable connection
- 6. Connections

Transformer protection unit (T1)

The transformer protection unit consists of a switch-disconnector and an earthing switch, equal to those present in the line unit. Besides, three fuses, having dimensions complying with the DIN Standards, are installed. Every fuse is inserted inside a fuse-holder, from which it can be frontally extracted after having opened the protection dust proof enclosure. The insulation between fuse and fuse-holder is of the solid-air type. The fuse-holders, manufactured in epoxy resin, are tight. Positioned the one on the other inside the switchgear hermetic housing, they are fully immersed in the gas SF₆. The fuses' position assures an easy replacement and a sure intervention by means of the striker. The extraction of a fuse is possible only if the same one is isolated and earthed both on the supply side and on the opposite one. A device makes the automatic opening of the control breaker when one or more fuses get blown; such device is actuated by the fuse striker. On the fuses protection dust proof enclosure, the mechanical signaling of blown fuse is foreseen.

The fuse rated current depends on the transformer power.

The fuse rated current depends on the following characteristics:

- service voltage,
- transformer power.

The installed fuses must comply with the IEC 60282-1 Standards and be dimensioned according with the DIN 43625 Standards. When the elimination of a fault corresponds to the blowing of either one or two fuses, it is recommended to replace all the three of them.

Legend

- 1. Fuse holder in epoxy resin
- 2. Cover in epoxy resin
- 3. Fuse
- 4. Air
- 5. Switchgear housing

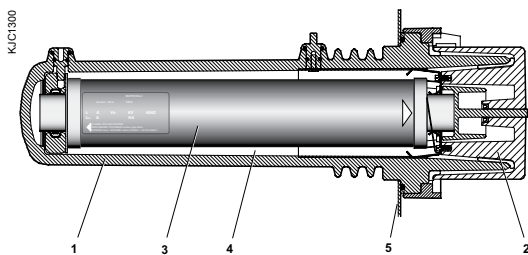

Fuse selection table

NB. As far as the performances on gray background are concerned, ask Schneider Electric.

KJ.C1400

Rated voltage	Transformer-capacity in kVA													
	100	125	160	200	250	315	400	500	630	800	1000	1250	1600	2000
Limit of short-circuit time	U _f = 4%						U _f = 5%			U _f = 6%				
							3 s			4 s				
kV	Rated current of high voltage fuse link in A													
6/7.2	20	25	32	40	50	63	80	100	125	160	200	250	-	-
10/12	16	16	20	25	32	40	50	63	80	100	125	160	200	-
15/17.5	10	10	16	16	20	25	32	40	50	63	80	100	125	160
20/24	10	10	16	16	16	25	32	40	63	63	0	00	100	125
36/36	6,3	10	10	16	16	20	25	25	32	40	40	50	63	-

Rated current values for (STANDARD) fuse
 Rated current values for (OUT-STANDARD) fuse

How to order the fuse

4101	XX	XXX
	kV	Ampere

Example 4101 | 36 | 040
36 kV 40 A

Unit with vacuum circuit-breaker (CB)

The CB unit consists of a vacuum circuit-breaker connected in series with respect to a three position-independent operation disconnector, allowing the insulation and the earthing of the line starting from the unit itself.

The disconnector's three positions are:

- a. service position
- b. disconnected position
- c. earthing position (in this condition it is possible to access to the cables compartment, in order to carry out the maintenance or to install the cables themselves).

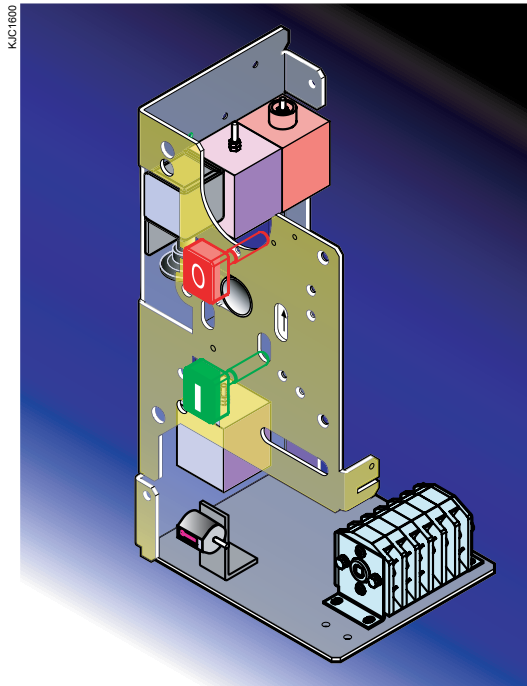
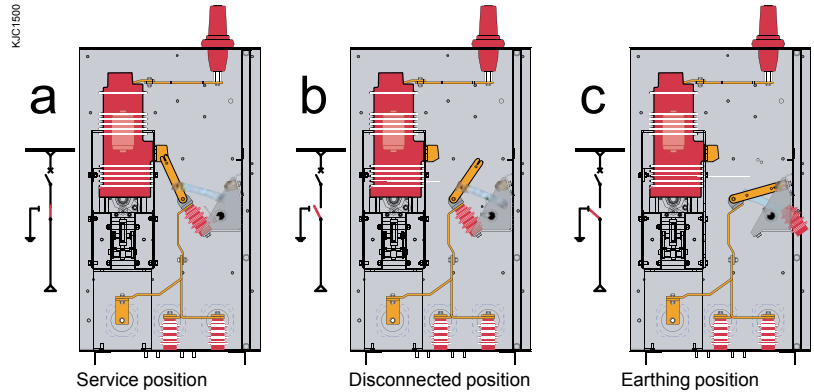

Accessories plate

The three position-disconnector operation is only possible provided that the circuit-breaker is open.

The circuit-breaker operating mechanism is of mechanical type, with energy accumulation and trip-free. It can be customized with a wide range of accessories, to be easily and quickly installed on a purposed accessory plate.

Such plate, realized in a single block and positioned on the circuit-breaker front side, allows to easily dismount/mount the accessories, so facilitating the possible replacement or maintenance interventions.

Upon request, the circuit-breaker unit can be equipped with a protection relay.

Direct incoming / outgoing unit (R)

The riser unit is used in order to translate in safety conditions a line from a point situated at a certain height to another point having a different height.

Outdoor switchgear

The FLUSARC switchgear can be equipped with a protected external structure, hermetically sealed in carbon sheet steel (P11) opportunely painted with a combined cycle making them apt for satisfying the insulation requirements necessary for granting a suitable protection against water, dust and humidity, with an IP54 protection class.

The apparatus is equipped with a front hatch with a telescopic cylinder opening lock, for acceding to the controls and carry out the routine operations. The cables' connection is frontal and the bushings are situated under the controls, protected by insulated protective boxes.



Outdoor switchgear



KJC1800



Operation counter

The FLUSARC switchgear are supplied in a basic configuration, which can be widened by a series of accessories available upon request.

Operation counter

The operation counter is a mechanical device, installed on the accessory plate. It executes the total count of the circuit-breaker closing-opening cycles.

KJC1800



Coil, Undervoltage release (UVR)

Undervoltage release (UVR)

This is a device which opens the CB when the auxiliary power supply drops below 35%.

It is available in the following versions:

- undervoltage release for circuit-breaker upstream auxiliary supply
- undervoltage release for circuit breaker downstream-auxiliary supply.

Voltage	Power consumption	
	Inrush	Continuous
24 Vdc	150 W	15 W
48 Vdc	150 W	15 W
110 Vdc	150 W	15 W
220 Vdc	150 W	15 W
110 Vac - 50 Hz	180 VA	25 VA
220 Vac - 50 Hz	180 VA	25 VA
110 Vac - 60 Hz	180 VA	25 VA
220 Vac - 60 Hz	180 VA	25 VA

KJC2000



Kit with mechanical override, Undervoltage release (UVR)

Undervoltage release control card

It supplies the undervoltage release. It includes a circuit sensitive to the voltage variations, which sends a tripping signal when the supply voltage lowers below a given value.

KJC2100



Undervoltage release control card

Shunt closing release

It is an electromechanical device which, after the energizing of an electromagnet, actuates the control tripping lever, so causing the circuit-breaker to get closed. The circuit breaker control includes the complete anti-pumping device.

KJC2200



Shunt closing release

Voltage	Inrush power consumption
24 Vdc	300 W
48 Vdc	300 W
110 Vdc	300 W
220 Vdc	300 W
110 Vac - 50 Hz	300 VA
220 Vac - 50 Hz	300 VA
110 Vac - 60 Hz	300 VA
220 Vac - 60 Hz	300 VA

K/C2200



Shunt opening release

Shunt opening release

It is an electromechanical device which, after the energizing of an electromagnet, actuates the control tripping lever, so causing the circuit-breaker to get open.

Voltage	Inrush power consumption
24 Vdc	300 W
48 Vdc	300 W
110 Vdc	300 W
220 Vdc	300 W
110 Vac - 50 Hz	300 VA
220 Vac - 50 Hz	300 VA
110 Vac - 60 Hz	300 VA
220 Vac - 60 Hz	300 VA

K/C2300



Demagnetisation opening solenoid

Demagnetization opening solenoid

The demagnetization opening solenoid is coupled with the VPR-SP1 self supplied protection relay. It is requested with all self-supplied relays.

K/C3300



Example of toroidal current transformer

Toroidal current transformer

The toroidal transformer measures the earth fault current. This device in closed core version has an inner diameter of 110 mm. The use of the toroidal transformer is recommended when the earth fault current is lower than 20% of the nominal value.

K/C2400



Gear motor for loading springs

Gear motor for loading springs

It automatically provides the loading of the springs, after a closing operation. It is equipped with an (anti-pumping) control circuit, which intervenes, when the OPEN and CLOSED commands are simultaneously present. In this case, the circuit-breaker gets back to the OPEN position, after having performed the closing. It keeps in that position, until a new closing command is sent out, so preventing the circuit-breaker from continuously opening and closing.

Voltage	Power consumption	
	Inrush	Continuous
24 Vdc	500 W	70 W
48 Vdc	500 W	70 W
110 Vdc	500 W	70 W
220 Vdc	500 W	70 W
110 Vac - 50 Hz	650 VA	90 VA
220 Vac - 50 Hz	650 VA	90 VA
110 Vac - 60 Hz	650 VA	90 VA
220 Vac - 60 Hz	650 VA	90 VA

K/C2500



Gear motor control card

KJIC2600



Feeder operating mechanism gear motor

KJIC2700



Line control gear motor control card

KJIC2800



Auxiliary contacts

KJIC8000



Voltage presence signal lamp

KJIC3000



Loaded or unloaded closing springs signalling contact

Line control gear motor

It automatically provides to open and to close the disconnecter. The gear motor is equipped with an electronic card, controlling its operation.

Voltage	Power consumption	
	Inrush	Continuous
24 Vdc	400 W	100 W
48 Vdc	400 W	100 W
110 Vdc	400 W	100 W
220 Vdc	400 W	100 W
110 Vac - 50 Hz	560 VA	140 VA
220 Vac - 50 Hz	560 VA	140 VA
110 Vac - 60 Hz	560 VA	140 VA
220 Vac - 60 Hz	560 VA	140 VA

Auxiliary contacts

They are open-closed signaling contacts. Two versions are available:

- 4 NO + 4 NC auxiliary contacts
- 6 NO + 6 NC auxiliary contacts

Electric characteristics of the contacts:

Un	Icu	Cos φ	T
500 V	15 A	0.4	-
220 V	1.5 A	-	10 ms

Voltage presence signal lamp

It signals the voltage presence on the three phases, supplied by capacitive voltage dividers.

It consists of a single block to be installed on the couplings already present on the panel.

Loaded or unloaded closing springs' signalling contact

Inserted in the electric circuit, it realizes the indication of the control closing springs' condition.

It is available in two alternative versions:

- loaded springs' signalling contact
- unloaded springs' signalling contact

KJC31MK



Diode rectifier bridge

Diode rectifier bridge

It is placed on the supply circuit of the shunt closing and opening releases' coils, if the auxiliary supply is of alternating current type.

KJC3200



Protection unit

Protection unit

Protection relay VPR-SP1

Self-power supplied, it controls the circuit-breaker intervention for the functions of: 50 - 51 - 50N - 51N.

Protection relay VPR-P1

Auxiliary-power supplied, it controls the circuit-breaker intervention for the functions of: 50 - 51 - 51N.

Any type of protection relay unit can be installed on customer request.

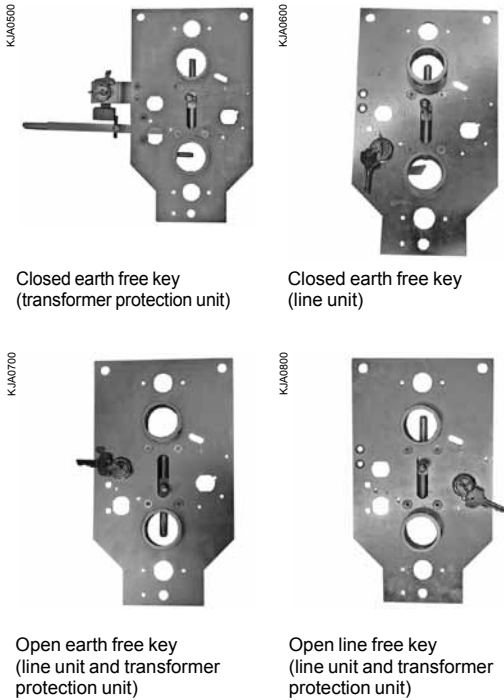

Safety system

In order to grant the operator's safety and to prevent the risk of wrong operations, the FLUSARC switchgear are equipped with the following safety devices (illustrated in paragraph **Product description**):

- controls and fuses protective boxes, which protect the operator from the moving parts and from the auxiliary voltages present inside;
- lower protective boxes, for protecting the cables and the bushings;
- pressure relief valves, installed in the lower part of the stainless steel housing, which assure the gas flow-off in case of a possible internal arc, without causing breaks on the front part, where the personnel charged with the electric operations could be possibly operating.

Besides the above mentioned, these additional safety devices are provided:

- key lock (optional), for preventing wrong operations when using the apparatus;



Door interlock device

- door interlock device, allowing to open the switchgear protective boxes only when the earthing switch is positioned on "closed earth";

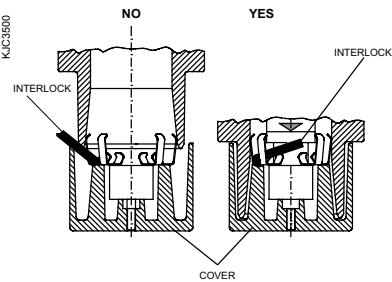

Fuse-holder cover interlock

- interlock on the fuse-holder cover, preventing to place the cover itself on the fuse-holder when the fuse is not mounted inside it, so preventing to put the apparatus into service;



Fuses compartment door mechanism

- device on the fuses compartment door, signalling the fuse blown condition through a colored indicator (white for fuse ok, red for fuse blown) and preventing the door itself to get closed when it was opened by blown fuse



Disconnecter control operation interlock device

- interlock device on the operation of the disconnecter control in the motorized switchgear, providing to cut out the power supply to the gear motor, so preventing its electric movement, in case the manual operating lever would get inserted.

All the controls are equipped with mechanical interlocks which prevent any wrong operation, so granting the utmost safety for the operator. The interlocks are the following ones:

- interlock between switch-disconnector and earthing switch. It prevents the earthing switch to get closed when the switch-disconnector is closed. In the same way, the switch-disconnector closing operation is prevented when the earthing switch is closed;
- interlock between circuit-breaker and disconnecter in the CB unit. When the interlock is shifted to the left, the circuit-breaker closing is prevented. When the interlock is shifted to the right, the disconnecter operation is prevented;
- interlock between disconnecter of the transformer protection unit and fuses compartment door. It prevents the opening of the fuses compartment door when the switch-disconnector is on closed position and the earthing switch is on open position.

Interlocks for functions C and T1

Position	Switch disconnector	Earthing switch	Access to fuses or cables compartment	
Switch disconnector	Closed	–	Locked open	Not allowed
	Open	–	Free	Dependant on the position of the earthing switch
Earthing switch	Closed	Locked open	–	Free
	Open	Free	–	Locked closed
Access to fuses	Open	Locked open	Locked closed	–
Access to cables compartment	Open	Locked open	<ul style="list-style-type: none"> ■ Free for C function ■ Locked / closed for T1 function 	–

Interlocks for function CB

Position	Circuit breaker	disconnector	Earthing switch	Access cover to cable compartment	
Circuit breaker	Closed	–	Locked (in closed position)	Locked open	Not allowed
	Open	–	Free	Dependant on the position of the disconnecter	Dependant on the position of the earthing switch
Disconnecter	Closed	Free	–	Locked open	Not allowed
	Open	Open	–	Free	Dependant on the position of the earthing switch
Earthing switch	Closed	Open	Open	–	Free
	Open	Dependant on the position of the disconnecter	Free	–	Not allowed
Access panel to the cable compartment	Open	Open	Locked	Free	–



Incoming/outgoing unit (C) commands and controls

Operator panels

Thanks to its well-structured layout and clear integrated functional diagram, the operator interface is designed to ensure safe operation.

Legend

1. Disconnecter switch state indicator
2. Disconnecter switch operating control
3. Line/earth controls mechanical interlock
4. Earthing switch operating control
5. Earthing switch state indicator
6. Voltage presence signal lamp (optional)



Transformer protection unit (T1) commands and controls

Legend

1. Disconnecter switch state indicator
2. Disconnecter switch operating control
3. Line/earth controls mechanical interlock
4. Earthing switch operating control
5. Earthing switch state indicator
6. Voltage presence signal lamp (optional)
7. Fuses compartment door handle
8. Fuse condition indicator
9. Fuses compartment door interlock

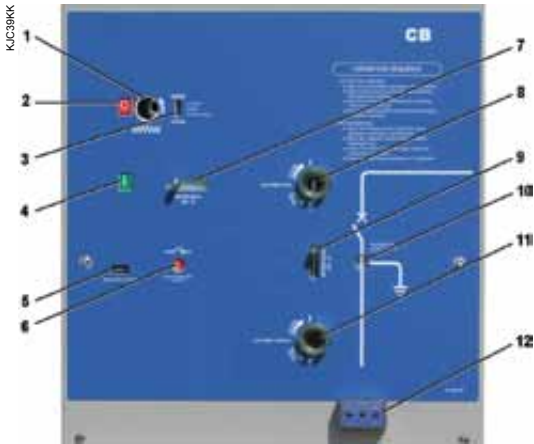

Legend

1. Circuit-breaker closing spring charged
2. Circuit-breaker opening control
3. Circuit-breaker closing spring state indicator
4. Circuit-breaker closing control
5. Operation counter
6. Circuit-breaker state indicator
7. Disconnect/circuit breaker controls mechanical interlock
8. Line side isolator operating control
9. Line/earth controls mechanical interlock
10. Disconnect/earthing switch state indicator
11. Earthing switch operating control
12. Voltage presence signal lamp (optional)

Commands and controls of the unit with vacuum circuit-breaker (CB)

At delivery, the switchgear is supplied in the following condition:
 ■ vacuum circuit-breaker open and opening and closing springs in the CB unit discharged;

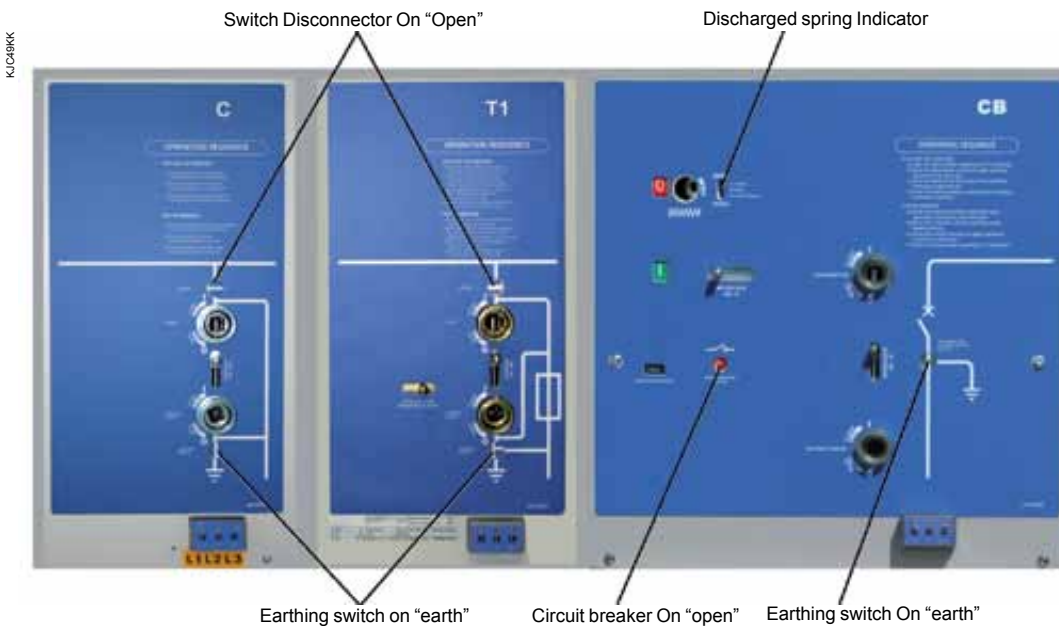

Position of the indicators at delivery



Circuit-breaker closing spring loading lever (CB unit)



Operating lever

■ switch-disconnectors open and earthing switch positioned on "earth".
 The operating accessories are available from Schneider Electric.
 The use of other auxiliary products and accessories is not permitted.
 Standard accessories supplied with the switchgear are operating lever and circuit breaker closing spring loading lever (CB unit).



Cables connection

Cables connection

The connection to FLUSARC switchgear is made easy by the frontal position of the insulator bushings, which is accessible via the simple removal of the cable cover box. The insulator bushings can be plug-in or inserted with screws type. The disconnectable cable terminals can be completely insulated or partially insulated. The following table describes the possible connections to FLUSARC switchgears.

CONNECTION	Rated current	Voltage
	400 A / 630 A	36 kV

Example of cable terminals

MANUFACTURER	Bushing screw	Bushing plug-in	36 kV		
			Rated current [A]	Connector	For cross section [mm ²]
Euromold			400	M400LR	185
			630	M400TB	35-185
ABB type			630	CSE-A 36	50-630
Pirelli			630	FMCT _S -400	25-300
NKT cables			250 / 400	CB 36-400	25-300
			630	CB 36-630	25-630
			630	CC 36-630	25-630

For other terminals cable type, ask Schneider Electric.



Disposal valve

For other terminals cable type ask Schneider Electric.

The switchgear satisfies to a high degree the ecological requirements in respect of environmental protection thanks to:

- optimization of material and energy consumption during manufacture;
- compliance with all ecological requirements during its service life;
- the use of recyclable materials for efficient disposal at the end of its service life.

Our design directive regarding environmentally compatible design specifies the use of materials which can be dismantled and are easily recyclable. The metals which form approximately 90% of the switchgear are easily recyclable. They can be 100% recycled as new metal components at the end of their service life.

Plastics can also be recycled. The thermosetting plastics can be fragmented and reused as fillers in other plastic components; the thermoplastic materials can be recycled in new plastic components. This means that the material is recovered, processed and reused in the manufacture of new parts.

To ensure efficient and environmentally friendly dismantling and sorting of materials by responsible disposal experts, all plastic components are identified accordingly. Moreover, material and utilization data sheets are available to provide the customer with an overview about the materials used, and the disposal company with important information regarding the recycling process.

Thus, the materials used for our products can be 100% recycled.

This provides a vital contribution to savings in global primary energy and material resources.

All materials were selected and developed so that, for example, switchgear affected by a fire in a building would have a minimal effect on the fire load (heat development and pollutants in the emissions).

Another important ecological aspect is the longevity of our products (approx. 30 years), which is an extremely long service life compared to other capital goods. Also, the FLUSARC switchgear units have been designed to require little maintenance, giving further energy and material savings, and to enable straightforward replacement of component parts, e.g. if new controllers have been developed (upgrading).

The high-voltage conducting parts of our gas-insulated switchgear units are hermetically sealed in an insulating inert gas (sulphur hexafluoride SF₆ which is neither reactive nor toxic).

Thus, all environmental influences which could reduce the service life are kept outside. The particular characteristic of the insulating gas also enables the overall size to be decreased by approximately 30% compared to switchgear without insulating gas designed with equivalent technical characteristics. This again saves on material and saves on the energy required to produce the material. The amount of insulating gas used in FLUSARC is approx. 0.5% of the total weight of the switchgear. Once the switchgear's service life has ended, the gas can be completely extracted via the disposal valve provided in each gas-filled compartment, and then recycled. To this end, the gas suppliers have developed an efficient recycling method.

In normal operation, the gas does not need refilling during the entire service life. The switchgear has been designed as a hermetically sealed pressure system according to IEC 60694 and EN 60694.

The FLUSARC switchgears are equipped with a base with drilling for fastening them to the floor.

KJAB000

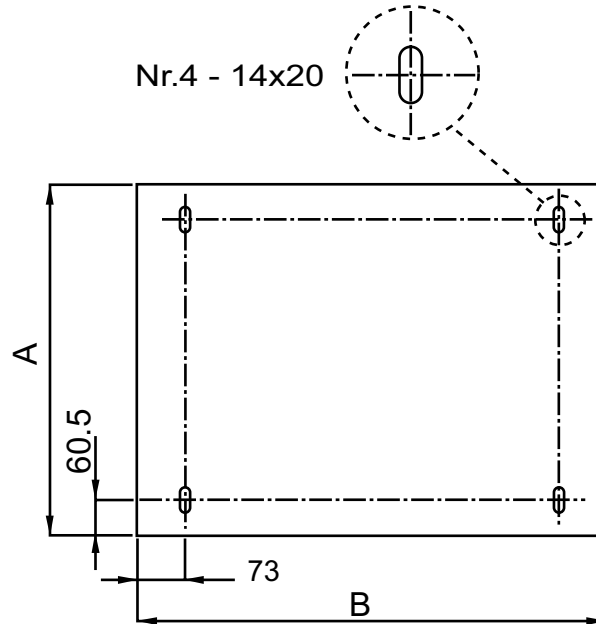

Dimensions mm	36 kV
A (depth)	615
B (width)	1276 / 2196

Base with drilling for realizing the switchgears fastening to the floor

In order to assure the fastening, use some expansion anchoring bolts in correspondence with the holes on the base, making sure that the bearing surface is perfectly horizontal and correctly leveled, with a planarity tolerance lower than 2 per thousand.



The dimensions are expressed in mm.

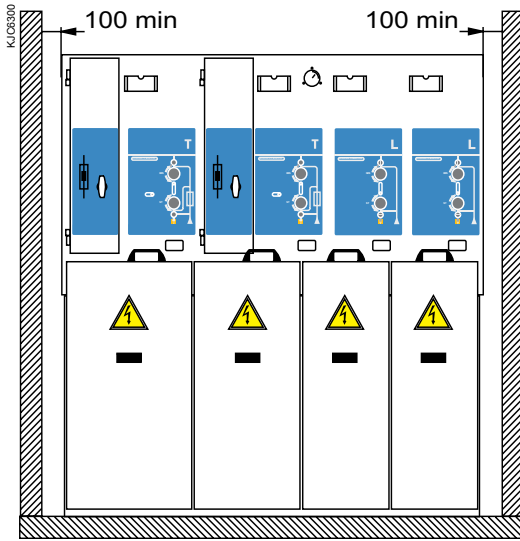

In the figure, the minimum distances to be observed during the switchgear installation are shown, both according with the installation room walls, and in order to allow to extract the fuses and to easily carry out the operations on the switchgear itself.

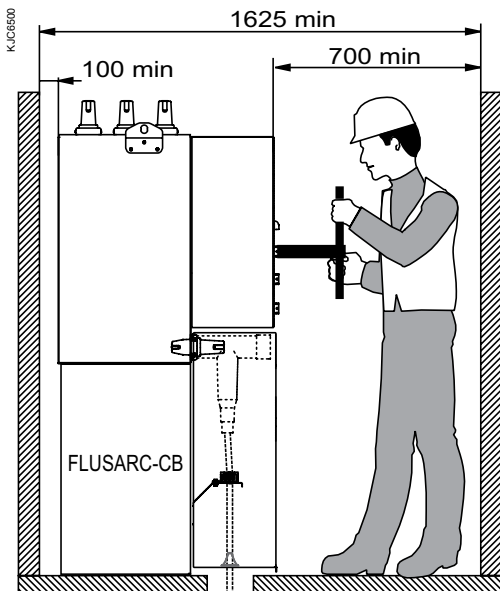
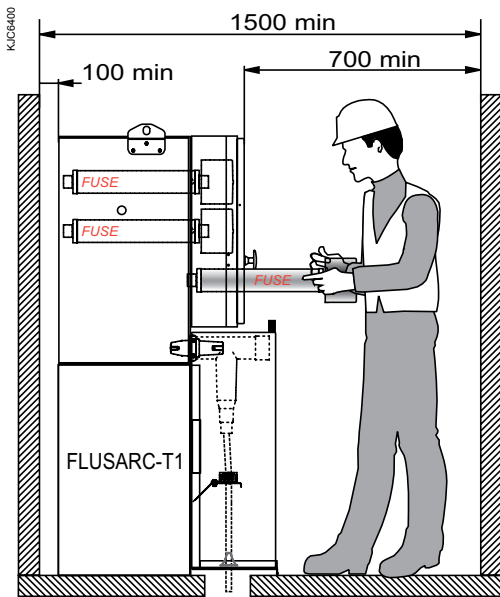

The foreseen distance of at least 100 mm between the apparatus rear part and the installation room wall must be absolutely observed, in order to allow a possible gas flow-off through the pressure relief valve.



The dimensions are expressed in mm.



Function	Number of panels		Height [mm]	Depth [mm]	Width [mm]	Weights approx. [kg]	
In / Out switchgear							
C-C-C	3-panel unit	36 kV	1720	920	1200	385 425 (°)	
Switching and transformer protection switchgear with fuse							
T1-C	2-panel unit	36 kV	1720	920	926	410 455 (°)	
T1-C-C	3-panel unit					1276	430 475 (°)
T1-C-C-C	4-panel unit				1626	510 555 (°)	
T1-T1-C-C	4-panel unit				1839	580 625 (°)	
T1-T1-C-C-C	5-panel unit				2189	640 685 (°)	
Modular switchgear							
C	Single-panel	36 kV	1720	920	500	200 245 (°)	
T1	Single-panel					580	250
R	Single-panel				500	185 (°)	
RE	Single-panel				500	190 (°)	
CB	Single-panel				550	256 296 (°)	
M	Single-panel				2000	1200	900
Ring main unit with CB							
CB-C-C	3-panel unit		36 kV	1720	920	1276	440 445 (°)

(°) motorized operating mechanism

Legend

- C Feeder with switch-disconnector
- CB Feeder with removable Veivacuum-L circuit-breaker
- R Direct incoming
- Re Direct incoming with earthing switch
- T1 Feeder with switch-disconnector and fuse holder
- M Busbar metering (CT VT) - on request, air insulated.



The dimension are expressed in mm.

KJCB200

Compact

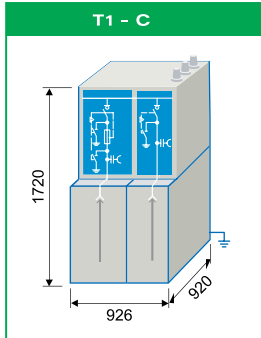

Ring main unit with CB

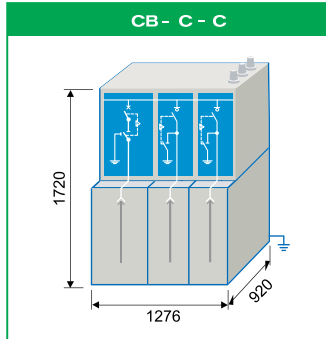

In/Out switchgear

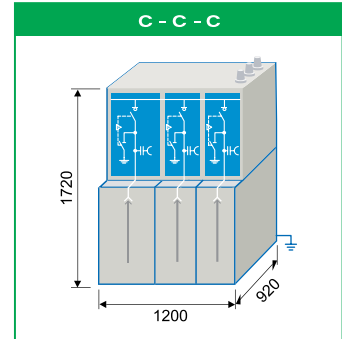

Switching and transformer protection switchgear with fuses

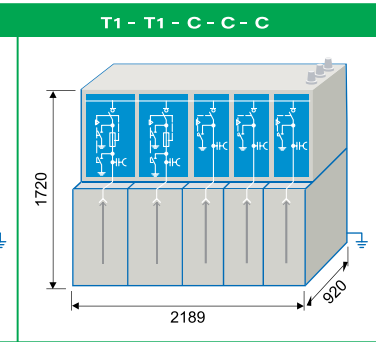
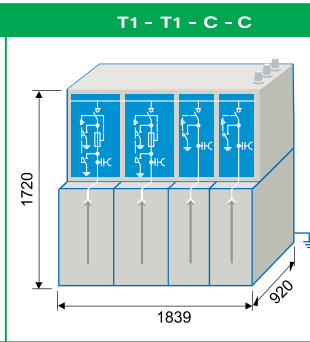
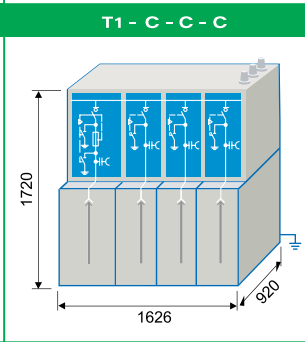
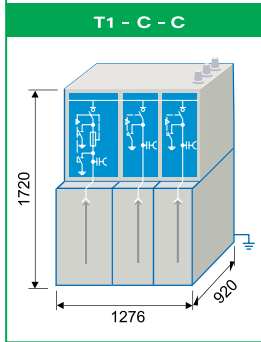

Modular switchgear

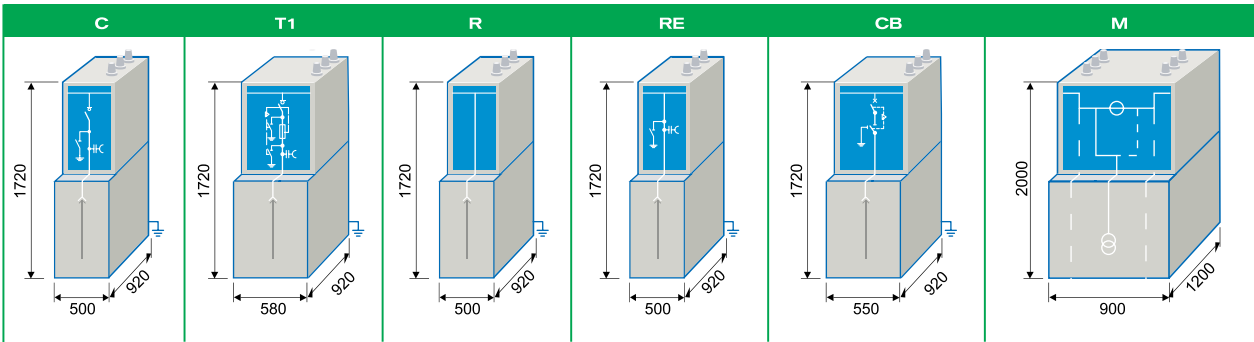

Outdoor switchgear

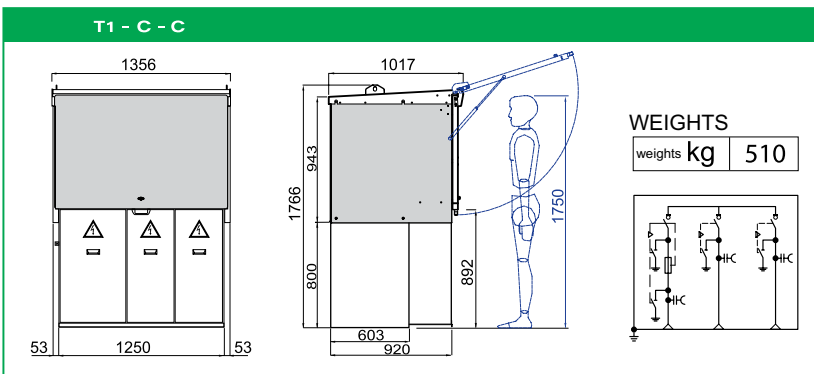

Reduced height versions available (1500 mm) on customer request

Packing



Strictly observe the symbols and the instructions indicated on the packing.

The FLUSARC switchgear are usually packed either inside a cardboard box or in a wooden case and firmly fastened at the base of a wooden pallet, but they can also be packed with other methods, according with the shipment and storing requirements and complying with the Customer requests.

The apparatuses are protected by polystyrene foam panels and wrapped in a water-proof plastic housing, in order to prevent any water infiltrations during the loading and unloading phases and to protect them from the dust during storage. Leave the equipment in its original packaging during storage. If units or parts are unpacked for checking, they must be repacked for continued storage, using the original packaging. Avoid condensation.

Transport

The motor vehicle used for the transport must be equipped with the loading platform realized in an ant-slip material with a high friction coefficient.

The switchgear must be positioned on the loading platform transversally back to back, by interposing materials fit for absorbing the compressions and for eliminating any possible direct contact of the surfaces of the different apparatuses.

On the loading platform, purposed longitudinal members must be disposed, in order to space every switchgear and to prevent both its longitudinal and its transversal shifting.

The different switchgear must be anchored to the motor vehicle structure by means of ropes, in order not to provoke deformations and to prevent their possible turnover on curves or in case of a sudden braking.

Besides, the motor vehicle used for the transport must be equipped with a covering sheet.

Handling



During the switchgear handling, it is recommended not to stress the possible cables connection bushings placed outside.

In order to lift the FLUSARC switchgear inside their packing, use a lift truck having an adequate lifting power with respect to the apparatus weight, by taking care to verify that the packing keeps perfectly balanced during the lifting phase.

KIC4400

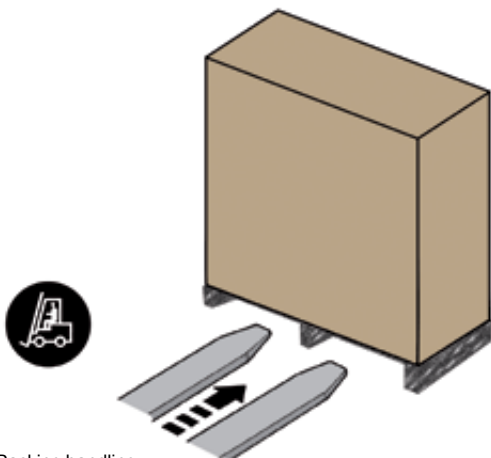

Packing handling

KIC4500

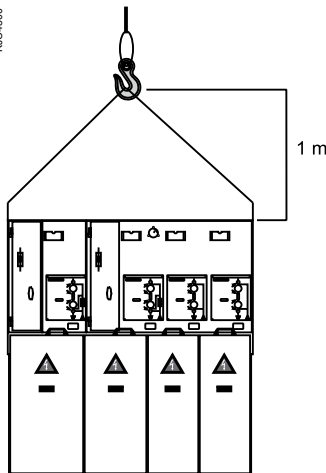

Packing handling

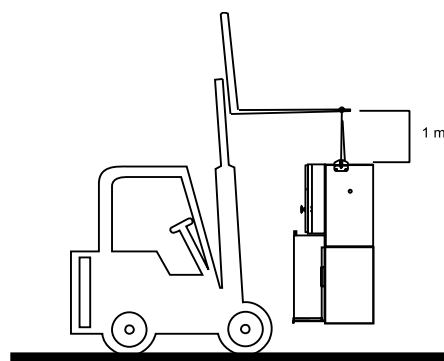

Schneider Electric
35, rue Joseph Monier
CS 30323
92506 Rueil-Malmaison Cedex, France

RCS Nanterre 954 503 439
Capital social 896 313 776 €
www.schneider-electric.com

As standards, specifications and designs change from time to time, please ask for confirmation of the information given in this publication.



*This document has been printed
on ecological paper*

Publishing: Schneider Electric
Design: Schneider Electric
Printing: