

Structure	Silicon Monolithic Integrated Circuit
Product series	6ch Power Driver for CD,DVD±RW,DVD-RAM
Type	BD7781AEFS
Characteristic	<ul style="list-style-type: none"> · 3-phase-sensor-less system, therefore don't need three hall sensors. · Output current detection resistor is not necessary with internally equipped detection circuit.

○Absolute maximum ratings

Parameter	Symbol	Limits	Unit
POWER MOS Power supply voltage	SPVM,SLVM	15 #1	V
Preblock/BTL powerblock Power supply voltage	Vcc, AVM,LDVM	15	V
PWM control block Power supply voltage	DVcc	7	V
Power dissipation	Pd	2.0 #2	W
Operating temperature range	Topr	-20~70	°C
Storage temperature	Tstg	-55~150	°C
Junction temperature	Tjmax	150	°C

#1 POWER MOS output terminals (8~10, 13~16pin) is contained.

#2 PCB (70mm×70mm×1.6mm,occupied copper foil is less than 3%,glass epoxy standard board) mounting.
Reduce power by 16mW for each degree above 25°C.

○Recommended operating conditions (Ta=-20~+70°C)

(Set the power supply voltage taking allowable dissipation into considering)

Parameter	Symbol	MIN	TYP	MAX	Unit
Spindle driver powerblock power supply voltage	SPVM	—	Vcc#3	—	V
Sled motor driver powerblock power supply voltage	SLVM	—	Vcc#3	—	V
Preblock power supply voltage	Vcc	10.8	12	13.2	V
Loading driver power block power supply voltage	LDVM	4.3	5.0	Vcc#3	V
Actuator driver powerblock power supply voltage	AVM	4.3	5.0	5.5	V
PWM control block power supply voltage	DVcc	4.3	5.0	5.5	V
Spindle driver output current	Iosp	—	1.0	2.5#4	A
Actuator/sled motor/loading motor driver output current	Ioo	—	0.5	0.8	A

#3 Set the same supply voltage to SPVM,SLVM and Vcc.

#4 The current is guaranteed 3.5A in case of the Short-circuit braking mode and the current which is turned on/off in a duty-ratio of less than 1/10 with a maximum on-time of 5msec.

This product isn't designed for protection against radioactive rays.

Status of this document

The Japanese version of this document is the formal specification.

A customer may use this translation version only for a reference to help reading the formal version.

If there are any differences in translation version of this document , formal version takes priority.

○Electrical characteristics

(Unless otherwise noted, Ta=25°C, Vcc=SPVM=SLVM=12V, DVcc=AVM=LDVM=5V, VC=1.65V, RL=8Ω, RLSP=2Ω)

Parameter		Symbol	MIN.	TYP.	MAX.	Unit	Condition
Circuit current	Quiescent current 1	IQ1	—	14	25	mA	Vcc (When Loading OFF)
	Quiescent current 2	IQ2	—	7	12	mA	Vcc (When Loading ON)
	Quiescent current 3	IQ3	—	6.5	11	mA	DVcc
	Standby-on current 1	IST1	—	0	100	μA	Vcc
	Standby-on current 2	IST2	—	0	100	μA	DVcc
Sled motor driver block	Input dead zone (one side)	VDZSL	0	20	80	mV	
	Input output gain	gmSL	0.75	1.0	1.25	AV	RSLLIM=3kΩ
	Output ON resistor	RONSL	—	2.2	3.0	Ω	IL=500mA
	Output limit current	ILIMSL	0.85	1.0	1.15	A	RSLLIM=3kΩ
	PWM frequency	fsl	—	100	—	kHz	
Spindle driver block	Input dead zone (one side)1	VDZSP1	20	55	90	mV	VLRPM=L
	Input dead zone (one side)2	VDZSP2	20	220	450	mV	VLRPM=H
	Input output gain H	gmSPH	2.3	3.0	3.7	AV	RSPLIM=1.3kΩ, VLRPM=L
	Input output gain L	gmSPL	0.46	0.6	0.74	AV	RSPLIM=1.3kΩ, VLRPM=H
	Output ON resistor	RONSP	—	1.1	1.7	Ω	IL=500mA
	Output limit current	ILIMSP	1.3	1.55	1.8	A	RSPLIM=1.3kΩ
	PWM frequency	fsp	—	167	—	kHz	
Focus driver block	Output offset voltage	VOFF	-20	0	20	mV	
	Output saturation Voltage	VOHF	—	0.7	1.6	V	IL=500mA
	Voltage gain H	GVFH	19.6	21.6	23.6	dB	VLRPM=L
	Voltage gain L	GVFL	13.6	15.6	17.6	dB	VLRPM=H
Tracking driver block	Output offset voltage	VOFT	-30	0	30	mV	
	Output saturation Voltage	VOHT	—	0.7	1.6	V	IL=500mA
	Voltage gain	GVT	19.6	21.6	23.6	dB	
Loading driver block	Output offset voltage	VOFLD	-50	0	50	mV	
	Output saturation Voltage 1	VOLD1	—	0.6	1.6	V	IL=500mA, LDVM=5V
	Output saturation Voltage 2	VOLD2	—	1.9	3.5	V	IL=500mA, LDVM=12V
	Voltage gain	GULD	15.5	17.5	19.5	dB	
Others	VC drop-muting	VMVC	0.4	0.7	1.0	V	
	Vcc drop-muting	VMVcc	3.45	3.85	4.25	V	

○Package outlines

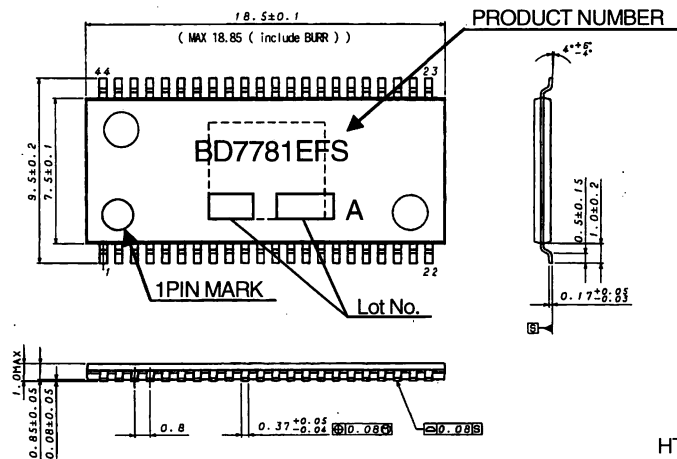

HTSSOP-A44 (UNIT : mm)

○Block diagram / Application circuit

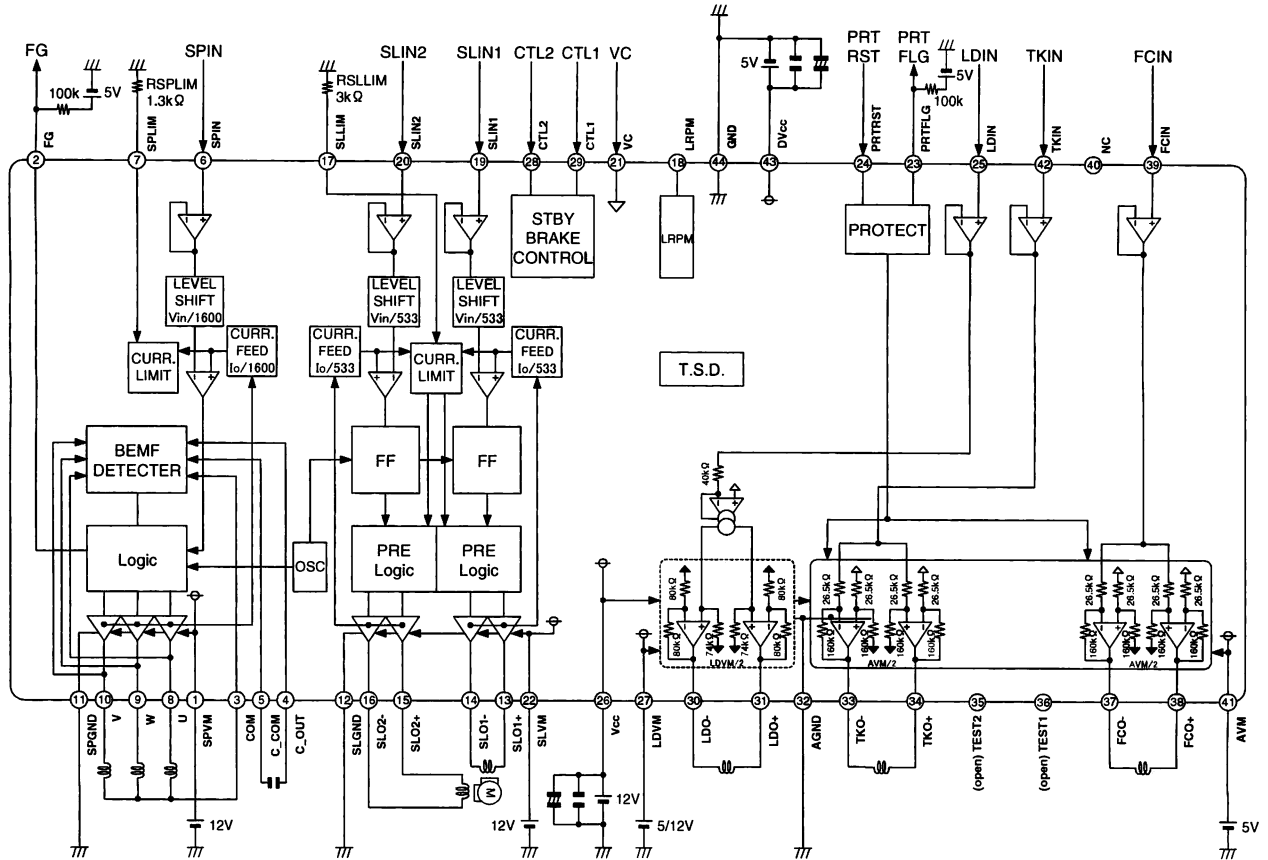

○Pin description

No.	Symbol	Description	No.	Symbol	Description
1	SPVM	Spindle driver power supply	23	PRTFLG	Protect flag output
2	FG	Frequency generator output	24	PRTRST	Protect reset input
3	COM	Motor coil center point input	25	LDIN	Loading driver input
4	C_OUT	Smoothing capacitor connection (output side)	26	Vcc	BTL pre power supply
5	C_COM	Smoothing capacitor connection (COM side)	27	LDVM	Loading driver power supply
6	SPIN	Spindle driver input	28	CTL2	Driver logic control input 2
7	SPLIM	Adjustable resistor connection for spindle driver current limit	29	CTL1	Driver logic control input 1
8	U	Spindle driver output	30	LDO-	Loading driver negative output
9	W	Spindle driver output W	31	LDO+	Loading driver positive output
10	V	Spindle driver output V	32	AGND	Actuator and loading motor driver power ground
11	SPGND	Spindle driver power ground	33	TKO-	Tracking driver negative output
12	SLGND	Sled driver power ground	34	TKO+	Tracking driver positive output
13	SLO1+	Sled driver 1 positive output	35	TEST2	Test pin2 (Please keep unconnected)
14	SLO1-	Sled driver 1 negative output	36	TEST1	Test pin1 (Please keep unconnected)
15	SLO2+	Sled driver 2 positive output	37	FCO-	Focus driver negative output
16	SLO2-	Sled driver 2 negative output	38	FCO+	Focus driver positive output
17	SLIM	Adjustable resistor connection for sled driver current limit	39	FCIN	Focus driver input
18	LRPM	Low-speed rotation mode switch terminal	40	N.C.	Non connection
19	SLIN1	Sled driver 1 input	41	AVM	Actuator driver power supply
20	SLIN2	Sled driver 2 input	42	TKIN	Tracking driver input
21	VC	Reference voltage input	43	DVcc	PWM block control power supply
22	SLVM	Sled driver power supply	44	GND	Pre-ground

●Positive/negative of the output terminals are determined in reference to those of the input terminals.

○Cautions in using the IC

1. Test pins
Please keep test-pins (TEST1, TEST2) unconnected.
2. Absolute maximum ratings
We are careful enough for quality control about this IC. So, there is no problem under normal operation, excluding that it exceeds the absolute maximum ratings. However, this IC might be destroyed when the absolute maximum ratings, such as impressed voltages (Vcc, PVcc) or the operating temperature range(Topr), is exceeded, and whether the destruction is short circuit mode or open circuit mode cannot be specified. Please take into consideration the physical countermeasures for safety, such as fusing, if a particular mode that exceeds the absolute maximum rating is assumed.
3. Power supply line
Due to switching and EMI noise generated by magnetic components (inductors and motors), using electrolytic and ceramic suppress filter capacitors(0.1μF) close to the IC power input terminals (Vcc and GND) is recommended. Please note: the electrolytic capacitor value decreases at lower temperatures.
4. GND line
The ground line is where the lowest potential and transient voltages are connected to the IC.G
5. Thermal design
Do not exceed the power dissipation (Pd) of the package specification rating under actual operation, and please design enough temperature margins.
6. Short circuit mode between terminals and wrong mounting
Do not mount the IC in the wrong direction and be careful about the reverse-connection of the power connector. Moreover, this IC might be destroyed when the dust short the terminals between them or GND
7. Radiation
Strong electromagnetic radiation can cause operation failures.
8. ASO(Area of Safety Operation.)
Do not exceed the maximum ASO and the absolute maximum ratings of the output driver.
9. TSD(Thermal shut-down)
The TSD is activated when the junction temperature (Tj) reaches 180°C(with +/-15°C hysteresis), and the output terminal is switched to Hi-z. The TSD circuit aims to intercept IC from high temperature. The guarantee and protection of IC are not purpose. Therefore, please do not use this IC after TSD circuit operates, nor use it for assumption that operates the TSD circuit.
10. Inspection by the set circuit board
The stress might hang to IC by connecting the capacitor to the terminal with low impedance. Then, please discharge electricity in each and all process. Moreover, in the inspection process, please turn off the power before mounting the IC, and turn on after mounting the IC. In addition, please take into consideration the countermeasures for electrostatic damage, such as giving the earth in assembly process, transportation or preservation.
11. Earth wiring pattern

This IC is a monolithic IC, and has P⁺ isolation and P substrate for the element separation. Therefore, a parasitic PN junction is formed in this P-layer and N-layer of each element. For instance, the resistor or the transistor is connected to the terminal as shown in the figure below. When the GND voltage potential is greater than the voltage potential at Terminals A or B, the PN junction operates as a parasitic diode. In addition, the parasitic NPN transistor is formed in said parasitic diode and the N layer of surrounding elements close to said parasitic diode. These parasitic elements are formed in the IC because of the voltage relation. The parasitic element operating causes the wrong operation and destruction. Therefore, please be careful so as not to operate the parasitic elements by impressing to input terminals lower voltage than GND(P substrate). Please do not apply the voltage to the input terminal when the power-supply voltage is not impressed. Moreover, please impress each input terminal lower than the power-supply voltage or equal to the specified range in the guaranteed voltage when the power-supply voltage is impressing.

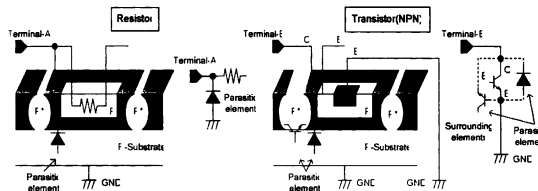

Simplified structure of IC

12. Earth wiring pattern
Use separate ground lines for control signals and high current power driver outputs. Because these high current outputs that flows to the wire impedance changes the GND voltage for control signal. Therefore, each ground terminal of IC must be connected at the one point on the set circuit board. As for GND of external parts, it is similar to the above-mentioned.
13. Reverse-rotation braking
In the case of reverse-rotation braking from high speed rotation, pay good attention to reverse electromotive force. Furthermore, fully check the voltage to be applied to the output terminal and consider the revolutions applied to the reverse-rotation brake.
14. About the capacitor between SPVM and SPGND
The capacitor between SPVM and SPGND absorbs the change in a steep voltage and the current because of the PWM drive, as a result, there is a role to suppress the disorder of the SPVM voltage. However, the effect falls by the influence of the wiring impedance etc, if the capacitor becomes far from IC. Please examine the capacitor between SPVM and SPGND to arrange it near IC.

Notes

- No technical content pages of this document may be reproduced in any form or transmitted by any means without prior permission of ROHM CO.,LTD.
- The contents described herein are subject to change without notice. The specifications for the product described in this document are for reference only. Upon actual use, therefore, please request that specifications to be separately delivered.
- Application circuit diagrams and circuit constants contained herein are shown as examples of standard use and operation. Please pay careful attention to the peripheral conditions when designing circuits and deciding upon circuit constants in the set.
- Any data, including, but not limited to application circuit diagrams information, described herein are intended only as illustrations of such devices and not as the specifications for such devices. ROHM CO.,LTD. disclaims any warranty that any use of such devices shall be free from infringement of any third party's intellectual property rights or other proprietary rights, and further, assumes no liability of whatsoever nature in the event of any such infringement, or arising from or connected with or related to the use of such devices.
- Upon the sale of any such devices, other than for buyer's right to use such devices itself, resell or otherwise dispose of the same, no express or implied right or license to practice or commercially exploit any intellectual property rights or other proprietary rights owned or controlled by
- ROHM CO., LTD. is granted to any such buyer.
- Products listed in this document are no antiradiation design.

The products listed in this document are designed to be used with ordinary electronic equipment or devices (such as audio visual equipment, office-automation equipment, communications devices, electrical appliances and electronic toys).

Should you intend to use these products with equipment or devices which require an extremely high level of reliability and the malfunction of which would directly endanger human life (such as medical instruments, transportation equipment, aerospace machinery, nuclear-reactor controllers, fuel controllers and other safety devices), please be sure to consult with our sales representative in advance.

It is our top priority to supply products with the utmost quality and reliability. However, there is always a chance of failure due to unexpected factors. Therefore, please take into account the derating characteristics and allow for sufficient safety features, such as extra margin, anti-flammability, and fail-safe measures when designing in order to prevent possible accidents that may result in bodily harm or fire caused by component failure. ROHM cannot be held responsible for any damages arising from the use of the products under conditions out of the range of the specifications or due to non-compliance with the NOTES specified in this catalog.

Thank you for your accessing to ROHM product informations.

More detail product informations and catalogs are available, please contact your nearest sales office.

ROHM Customer Support System

THE AMERICAS / EUROPE / ASIA / JAPAN

www.rohm.com

Contact us : webmaster@rohm.co.jp